

# SR65 LI

Wireless outdoor light sensor for automatic control of shading

**thermokon**<sup>®</sup>  
HOME OF SENSOR TECHNOLOGY

## Datasheet

Subject to technical alteration  
Issue date: 19.05.2016



## Application

Wireless light sensor for blind systems. Can also be used to control light at sunset. Configuration via airConfig.

## Security Advice – Caution



The installation and assembly of the device should only be performed by authorized personnel.

The product should only be used for the intended application. Unauthorised modifications are prohibited! The product must not be used in relation with any equipment that in case of a failure may threaten, directly or indirectly, human health or life or result in danger to human beings, animals or assets. Ensure all power is disconnected before installing. Do not connect to live/operating equipment.

Please comply with

- Local laws, health & safety regulations, technical standards and regulations
- Condition of the device at the time of installation, to ensure safe installation
- This data sheet and installation manual

## Notes on Disposal



As a component of a large-scale fixed installation, Thermokon products are intended to be used permanently as part of a building or a structure at a pre-defined and dedicated location, hence the Waste Electrical and Electronic Act (WEEE) is not applicable. However, most of the products may contain valuable materials that should be recycled and not disposed of as domestic waste. Please note the relevant regulations for local disposal.

## Guidelines for Devices with Solar Energy Storage

Due to the energy-optimized EnOcean radio technology used in "EasySens" wireless sensors, the devices can work without batteries and self-charge themselves using electric energy generated by integrated solar cells. This makes the devices almost maintenance free and environmentally sound due to not having to replace batteries.

For optimum use, the device should be mounted in a location with sufficient ambient brightness. Minimum illumination of 200 lx (artificial light or ambient) is required for at least 3 to 4 hours each day. (The health and safety regulations at work require a minimum illumination of 500 lx for office workplaces).

The solar cell should be mounted facing towards the window direction if possible. If the device has a temperature sensor, then even periodic direct sun radiation should be avoided due to incorrect false temperature readings.

The mounting position should be selected so that the device will not be obstructed in the future: for example by placement areas, additional furniture or roll-fronted cupboards.

The sensor is supplied in an operational state. If the sensor has been stored in darkness for longer periods, the internal solar energy storage will most likely need to be recharged. This would normally happen automatically during commissioning or during initial start up in ambient light. If the initial charge is not sufficient, the sensor will reach its full operating state up to 3 to 4 days, if the requirements for minimum illumination per day are met. The sensor will then transmit continuously in darkness as specified (2/3 days on factory default telegram timing). Depending on the application it is also possible for the devices to operate in darker rooms (with brightness <100 lx) by using the battery back-up option. Batteries to be used are listed in accessories.

The operating time when using batteries will depend on the transmission frequency as well as the component aging and the self-discharge of the battery. Standard operating time will be 5-10 years on factory default telegram timing. Changing of the device from solar to battery operation is done automatically by simply adding a battery to the device.

## Information about EasySens (Radio) / airConfig in general

See Information: [http://www.thermokon.de/ftp/info/Information\\_Radio\\_airConfig\\_en.pdf](http://www.thermokon.de/ftp/info/Information_Radio_airConfig_en.pdf)



## Technical Data

Measuring values	Light
Radio technology	EnOcean (IEC 14543-3-10)
Frequency	868 MHz
Power supply	Solar cell, internal super cap, maintenance-free, optional: battery LS14250 3,6 V
Measuring range light	Configured via airConfig, 0..510 Lux, 0..1000 Lux (10 Bit), 0..1020 Lux, 300..30.000 Lux (default), 600..60.000 Lux
Transmission interval	Configured via airConfig, Default: Wake-up time =100 sec. Heartbeat cycle = 10x
Enclosure	PA6, pure white with quick lock screws
Protection	IP65 according to EN60529
Ambient condition	-20..+70 °C, max. 85% rH, short term condensation
Weight	110 g

## Overview of airConfig selectable radio telegrams

- A5-06-01 (300..30.000, 600..60.000 Lux)\*  
\*factory default: A5-06-01 (300..30.000 Lux)
- A5-06-02
- A5-06-03

## EEP:

The structure of the data contained in the telegram can be found in the EEP (EnOcean equipment profile) list provided by the EnOcean Alliance: <http://www.enocean-alliance.org/EEP/>.



## Configuration with airConfig

NO airConfig needed if default settings will be used. airConfig and a EnOcean USB transceiver (i.e. USB300) will be mandatory if the default EEPROM and other settings shall be changed.

The screenshot shows the 'Settings' window of the airConfig software. It is divided into two main sections: 'Device information' and 'Device settings'.

**Device information:**

- Firmware version: 1.00
- Energy status: n/a

**Device settings:**

- Change of value: 117 lux
- Lux offset: 0
- EEP: A5-06-01 (300-30k lx)
- Wake-up time: 10 sec
- Heartbeat cycle: every 10th WakeUp

The device information shows the installed **Firmware version** and the current **Energy status** of the device is full charged or a battery is inserted. The Energy status must be **OK** to configure the device.

**Change of value** defines the minimal measured change of value required since the last transmission to send a new telegram. Set **Lux offset** for individual adjustment.

Clicking on the drop-down menu **EEP** to choose the desired measuring range. The **Wake-up time** defines the measuring interval. **Heartbeat cycle** defines the maximal number of Wake-ups without transmitting the temperature between 2 transmissions. Receivers monitor this interval to detect missing sensor signals.

Right-click on the device icon and send configuration to initiate the transfer of the new settings. As the sensor will be sleeping it will need to be woken up by pressing the LRN button. Once the configuration has been transferred successfully into the device the sensor will be highlighted in green. Highlighted in Red indicates a problem during the transmission.

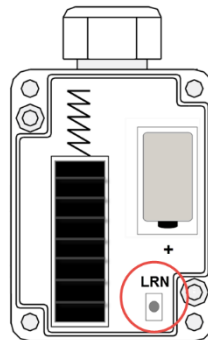

**Note:**

The more frequently a device is programmed to wake up, measure and send data, the more energy is being consumed, which can lead to insufficient energy charge of the sensor by ambient illumination.

### Dimensions (mm)

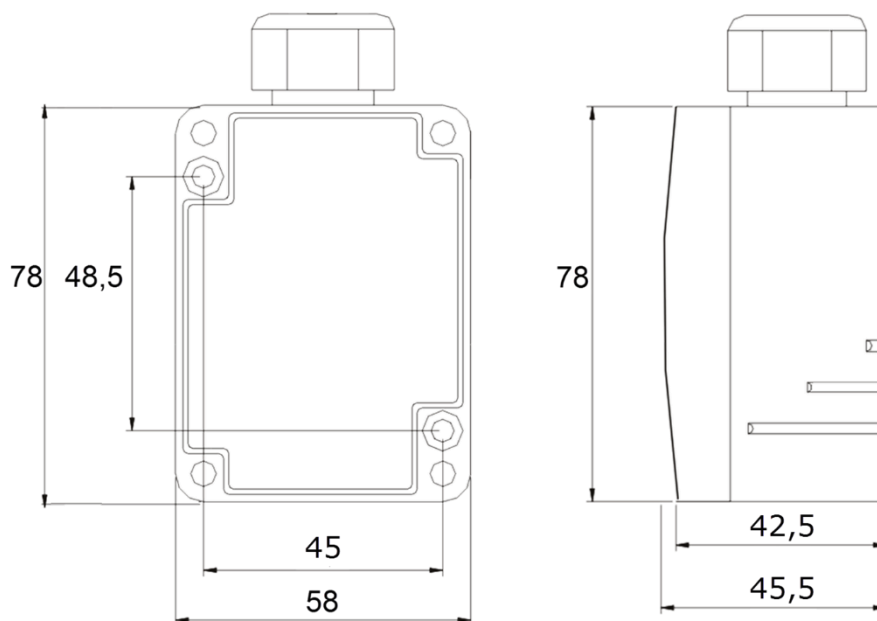

### Accessories (optional)

Battery LS14250  
Raw plugs and screws (each 2 pieces)

Item No. 315098  
Item No. 102209